



Competition Regulations 2007-2008

**Rules Governing Model Aviation
Competition in the United States**

Radio Control Scale Aerobatics

Amendment Listing

Original Issue	1/1/2007	Publication of Competition Regulations
----------------	----------	--

RADIO CONTROL SCALE AEROBATICS

For event 411, 412, 413, 414, 415.

1. Objective. To duplicate full-scale aerobatics with miniature radio controlled aircraft in a realistic manner that is challenging for the contestants as well as interesting for the spectators.

2. General. All AMA regulations and FCC regulations covering the RC flier, airplane and equipment, shall be applicable to this event.

2.1. Consideration of safety for spectators, contest personnel, and other contestants is of the utmost importance in this event. Any unsportsmanlike conduct or hazardous flying over a controlled spectator area will be cause for immediate disqualification of that flight. Further infractions will result in the removal of that pilot from the contest.

• 3. Open Events.

3.1. The events accommodate aerobatic monoplanes and biplanes which are replicas of types known to have competed in International Aerobatic Club (IAC) competition, or replicas of types known to be capable of aerobatic competition within the airspace known as the "Box."

3.2. All classes except Basic require that the pilot must meet the requirements defined in Rule 3.1. The Basic Class is open to all competitors with a monoplane or biplane aircraft. There is no minimum size requirement for any class. Contest Directors may make an exception for a model of a full scale aircraft that was built for IAC competition, but has not yet competed. Proof of the latter is the responsibility of the contestant.

3.3. The known sequences will be developed, annually, by the IMAC Sequence Committee, in accordance with the current FAI "Aresti System (Condensed)". The IMAC Board of Directors must approve all known sequences for use in IMAC competition.

• 3.4. The unknown sequences will be drawn from the Catalog of Legal Unknown Figures for each class. The Catalog of legal Unknown Figures is located in the Rules Section of the IMAC Website.

3.5. Difficulty of "K" factors for known and unknown sequences will be derived from the current FAI "Aresti System (Condensed)".

• 4. Model Aircraft Specifications.

4.1. Only one (1) propeller per aircraft shall be allowed. Internal combustion reciprocating engines and electric motors shall

be allowed. If the aircraft is utilizing an internal combustion engine, only one (1) engine shall be allowed. If the aircraft is utilizing electric motors, more than one (1) electric motor may be used.

4.2. The model shall comply with all AMA Safety Codes.

4.3. There shall be no airborne devices fitted to the aircraft which place the aircraft under less than total control by the pilot. These devices will include, but are not limited to, gyros, automatic pilots and timing devices. Non-airborne aids such as transmitter based functions are permissible.

4.4. The Builder-of-the-Model (BOM) rule shall not apply.

5. Scale Aerobatic Sound Limits.

5.1. Maximum Sound Levels. The maximum ground sound level for all classes shall be: 96dBA measured on soft surfaces and 98dBA measured on hard surfaces. Contest Directors may implement a correction factor due to unusual conditions.

5.2. Standard Method of Sound Measurement. The sound measurement shall be taken with the sound meter set to the "A" weighting, slow response with windscreen installed. The sound meter shall be placed downwind, twenty-five feet from the model centerline and positioned in line with the prop arc at twenty-four inches in height (see Fig. 1). The sound meter shall be pointed directly at the model and perpendicular to the fuselage. The model being measured shall have its engine run at full power for the sound test. No noise reflecting objects will be allowed within three feet of the sound meter.

5.3. Ground Sound Level Test. Prior to flying the first round of a contest; each competition model must pass the Ground Sound Level Test. The Ground Sound Level Test must be completed at the sanctioned contest site by the Contest Director or his/her designee. Testing shall be done in an area designated by the Contest Director and may be completed prior to or during the first round. Models successfully completing the test will not be measured again during the contest unless their sound level is deemed to have increased significantly since the initial check by the Contest Director. Any plane that fails the test will not fly, but will be moved to the back of the flight order, and allowed one more attempt to pass the test. Any model that fails the second test will zero all judged

sequences he would have flown during the current round. Any model that fails the second test may be tested again during future rounds with the same Ground Level Sound Test criteria being applied. No model will fly any judged sequences at any Scale Aerobatics contest until it passes the Ground Sound Level Test.

5.4. In-Flight Judging Criteria, Known and Unknown Sequences. Judges will evaluate each Fig. 1

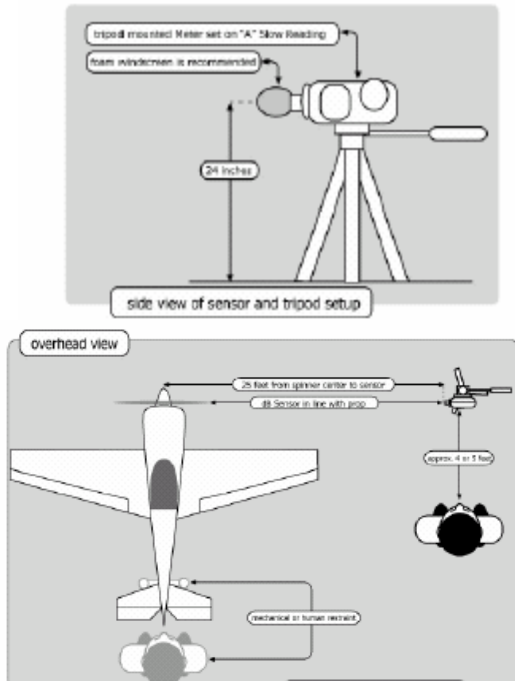

individual sequence flown in its entirety for overall sound presentation. Each judged Known and Unknown sequence, shall have one “figure” added to the end of the score sheet after individually judged maneuvers. This figure shall be known as the Sound Score. The Sound Score will have a K value dependent on the class flown. Individual class K values shall be: Unlimited 5 K, Advanced 4K, Intermediate 3K, Sportsman 2K, and Basic, 1K. The bottom of each score sheet shall contain three boxes, Too Noisy, Acceptable and Very Quiet. Judges will mark one of the boxes for each sequence flown. These boxes shall translate in the computer to a score of: Too Noisy - 0, Acceptable - 5, Very Quiet - 10. This score will then be multiplied by the K value for the individual class. If two judges are utilized, both judges’ scores must concur to issue a Too Noisy penalty or a Very Quiet bonus. In absence of a Too Noisy or Very Quiet concurrence, an Acceptable will be scored for each sequence flown. If three or more judges are

utilized, a simple majority concurrence will issue a Too Noisy penalty or Very Quiet bonus. All Pilots that receive a Too Noisy penalty shall be notified of the penalty by the Contest Director prior to the next round. Pilots that receive a Too Noisy penalty will be allowed to adjust the aircraft setup and fly the next round (Known Unknown). Any pilot, who receives a second Too Noisy penalty during any Known, or Unknown, will be disqualified from further competition at that contest.

• 6. Proof of Scale.

6.1. To prove that the model resembles a particular aircraft some proof of scale is required.

6.2. Proof of scale is the responsibility of the contestant.

6.3. The general outlines of the model shall approximate the full size outlines of the subject aircraft. Exact scale is not required. The model shall be judged for likeness at a distance of approximately 10 feet.

6.4. If the contestant presents no proof of scale material with the model, and the CD can determine that the aircraft is a replica of a full-size aircraft, then the contestant will be allowed to have his/her entry considered.

• 6.6. Scale shall be determined by the wingspan. A change in wingspan will become a change in overall Scale. Fuselage width, height and aircraft planform or any other variations shall not exceed 10% of scale, with the exception of airfoils and size/shape of control surface within the scale outline rule.

6.6. A realistic three-dimensional human pilot and viewable instrument panel shall be appropriately installed in all Scale Aerobatic aircraft. (A one [1] percent flight score penalty will be assessed for noncompliance.)

7. Material and Workmanship. Workmanship must be of satisfactory standards. The Contest Directors are empowered to refuse permission to fly, or to disqualify any aircraft which, in their opinion, is not up to reasonably safe standards in materials, workmanship, or radio installation.

8. Competition Classes.

• 8.1. The event shall be divided into five (5) classes, in order of increasing difficulty. The classes are Basic (411), Sportsman (412), Intermediate (415), Advanced (413), and Unlimited (414).

8.2. An Optional Four (4) Minute Freestyle may also be offered. A pilot must compete in one of the above classes to be eligible for the freestyle event.

8.3. Contest Directors and/or the sponsors of a sanctioned meet shall determine which of the classes and events will be flown. Such information must accompany all advance notices pertaining to the contest, including any planned deviation from standard rules, at least 30 days prior to the date of the contest.

9. Contestant Classification.

9.1. A contestant may enter any one competition class at their own option. Once entered, a contestant may not move down in class without written permission from their regional director.

Should their class not be offered at a contest, the contestant may enter the next highest class, and then return to their normal class at the next contest where their normal class is offered. If a Basic thru Advanced class contestant wins 5 contests with 4 or more competitors in a calendar year, they must advance to the next higher class at the beginning of the next calendar year.

9.2. The new contest season begins when the annual aerobatic sequence changes are approved by the IMAC Board of Directors and made available to the IMAC membership on the IMAC website at the start of each calendar year.

9.3 There shall be at least four (4) entries in the winning contestant's class who make official flights before the first place victory is counted towards advancement.

• 10. Official Flights.

10.1. Official flight for known program.

10.1.1. An official flight (round) for the known program is defined as two (2) sequences. When time constraints prevent two (2) sequences from being flown, a round may consist of one (1) sequence. Contestants shall have one attempt per sequence to complete the sequence. An attempt is made when the pilot or caller announces that he/she is entering the aerobatic airspace or the aircraft rocks the wings at entry.

10.1.2 If a known sequence in progress is determined by the judges to have been interrupted by a circumstance beyond the control of the contestant, the contestant may resume the sequence with the next unscored maneuver.

• 10.1.3. If a known sequence in progress cannot be completed due to mechanical problems with the aircraft (including but not limited to engine failure, radio malfunctions, etc.) the contestant will receive zeros (0) for each unscored maneuver in that sequence. If the second sequence is yet to be flown and the aircraft can be made ready to fly (refer to rule 8), the contestant may attempt the second sequence.

10.2. Official flight for unknown program.

10.2.1. An official flight (round) for the unknown program is defined as one (1) sequence. Contestants shall have one attempt to complete the sequence. An attempt is made when the pilot or caller announces that he/she is entering the aerobatic airspace or the aircraft rocks the wings at entry.

10.2.2. If an unknown sequence in progress is determined by the judges to have been interrupted by a circumstance beyond the control of the contestant, the contestant may resume the sequence with the next unscored maneuver.

10.2.3. If an unknown sequence in progress cannot be completed due to mechanical problems with the aircraft (including but not limited to, engine failure, low fuel, radio malfunctions, etc.), the contestant will receive zeros (0) for each unscored maneuver in that sequence.

11. Number of Flights. There shall be no limit on the number of flights (other than that imposed by time available).

• 12. Aerobatic Airspace.

Refer to Flying and Judging Guide, Rule 4.1.

13. Time Limits.

13.1. The contestant has two (2) minutes to start his/her engine and become airborne. If after two (2) minutes the contestant is unable to start the engine, they will move to the end of the round rotation. If the contestant fails to start a second time, they shall receive zero for the round.

13.2. The contestant has one (1) minute from the time the wheels leave the ground during takeoff to enter the aerobatic airspace.

13.3. There shall be no time limit while in the aerobatic airspace.

13.4. The contestant has two (2) minutes between leaving the aerobatic airspace and touchdown for landing, unless required to hold upon command from the appropriate official.

13.5. Prior to entering the aerobatic airspace, pilots shall be allowed to perform only the following trim and positioning maneuvers; turns; ½ Cubans (or reverse), with only a single ½ roll on the 45 line; ½ loops, up or down, with only a single ½ roll on entry or exit; single ½ roll to inverted immediately prior to entering the aerobatic airspace. Such maneuvers may not be performed at low altitude or directly in front of the judges. No other aerobatic maneuvers are allowed immediately following the airplane breaking ground (except for the Four Minute Freestyle). Upon exiting the aerobatic airspace

pilots shall be allowed to perform only the following positioning maneuvers; turns, ½ loops down, with only a single ½ roll on entry or exit; single ½ roll to upright; in preparation for executing a safe landing. No other aerobatic maneuvers are allowed. Any infraction shall result in a penalty of zeroing the round.

14. Point System.

14.1. All classes shall have the scheduled maneuvers scored on a scale of 10-0. Half (.5) points may be used in judging. Points are deducted for imperfections as per the Scale Aerobatics Official Flying and Judging Guide.

14.2. Degree of difficulty factor (K-factor) values shall be assigned to individual maneuvers based upon the current FAI catalog of maneuvers, with modifications as required by the International Miniature Aerobatic Club (IMAC). When calculating contestant scores, each individual maneuver score shall be multiplied by its K-factor. The flight score shall be the result of summing the “K-factored” (maneuver score multiplied by K-factor) scores.

15. Determining Placement.

15.1. Sequence scoring.

- a. Scoring –The Official IMAC Contest guide shall be used to determine the number of sequences to be scored (drop schedule) and the weight of the unknown(s) based on contest category (2 day, multi-day, regional, etc).

<u>Total Sequences Flown</u>	<u>Number of Sequences to drop</u>
Less than three (3)	Zero (0)
From three (3) to five (5)	One (1)
Six (6) and greater	Two (2)

- b. Unknowns – Each unknown sequence shall be flown once. The Official IMAC Contest Guide shall be used to determine how the known scores and unknown scores are combined based on contest category.
- c. Combined Scores – The highest combined scores will determine the winner.
- d. Normalization – All sequences will be normalized to 1000 as outline in Rule 16.4.

15.2. In the case of ties, the best non-scored sequence of the contestant shall be used to determine the winner.

15.3. The same set of judges shall judge each round. Judges may be rotated between rounds.

15.4. Each sequence shall be normalized to a standard 1000 points. The pilot with the highest raw score receives 1000 points for the round. Each pilot thereafter shall have their raw score divided by the high raw score giving a percentage of that high raw score, which is then multiplied by 1000 to get the normalized score. Scores shall be rounded to two (2) places of decimal accuracy. For example: Contestant A wins the round with a raw score of 4850 points. Contest B is second with 4766.5 points. Contestant A receives 1000 points for the sequence. Contestant B’s score is 982.78 points (4766.5 divided by 4850 = 0.982783 * 1000 for 982.783, which rounded to two (2) places of decimal accuracy for a final score of 982.78).

• 16. Flight Pattern.

17.1. A contest shall include one (1) or more rounds of Known sequences and may include one (1) or more Unknown sequences. Any given unknown sequence can only be flown once per contest.

16.2. Compulsory Known Maneuver Sequences are defined by rule 3.3.

•16.3. Optional Unknown Maneuver Sequences shall include separate Sportsman, Intermediate, Advanced, and Unlimited sequences, each consisting of up to 15 maneuvers.

a. Unknowns shall be distributed the day of the contest or the night before to allow pilots to mentally fly and visualize them. If a contestant is found to have practiced the Unknowns with a flying model or on a computerized flight simulator, that contestant will be disqualified from the entire contest.

b. Flight order for the Unknowns should be established by random drawing.

•16.4. The contestant must fly his entire flight according to the established flight schedule for his particular class and in the sequence listed. Maneuvers that are executed out of sequence, or not executed as required by the sequence, will be zeroed. Remaining maneuvers that are flown in their appropriate area and in the appropriate order following the zeroed maneuver will be scored.

16.5. Takeoff and landing are not to be considered judged maneuvers. It is not necessary for the judges to see the aircraft take off or land. The aircraft may be carried to the takeoff point, and carried from the landing area, if so desired.

• 17. Four (4) Minute Freestyle Program.

17.1. The four (4) Minute Freestyle Program is a “Show Time” separate event. It is an unrestricted, individually crated sequence in

which “Anything Safe Goes!” To be eligible to participate and compete in this event, the competitor must also compete in one of the five IMAC categories of precision sequence flying at the same event. It should have separate awards when offered. It is graded on the following criteria:

A. Technical Merit {90 K}

a.1. Complete Use of the Flight

Envelope Utilizing the Exploitation of Aerodynamic and Gyroscopic Forces (20 K). The pilot is expected to make full use of the flight envelope of the aircraft. This means flying the full range of airspeeds and accelerations permitted.

Program time should be divided between high and low speeds, high and low G maneuvers, and both positively and negatively G loaded flight segments. The flight should include the demonstration of controlled flight beyond the stall boundary by use of autorotation or other high angle of attack maneuvers. The judge will deduct points if any of these areas are noticeable under utilized.

The pilot is expected to show movement of the aircraft about all axes using both conventional aerodynamic controls and propeller-generated gyroscopic forces. Higher grades will be given to pilots able to make use of all these effects through a wide range of aircraft attitudes and flight paths. Repeated use of any such forces in the same or similar attitudes should result in lower scores.

a.2. Execution of Individual Maneuvers (40 K). It should be clear that the maneuvers flown were, in fact, intended and fully under the pilot’s control. Higher marks will be given for this objective when individual maneuver elements are started and finished on obviously precise headings and in well defined attitudes.

When, for example, gyroscopic maneuvers are allowed to decay into imprecise, poorly defined autorotation, marks should be deducted for poor execution. Marks should also be deducted if it appears that the pilot has relinquished control the aircraft at any time.

a.3. Wide Variety of Figures Flown on Different Axes and Flight Paths (30 K). Many different figures should be completed in the time available. These should include maneuver elements of many different kinds and should use many different flight paths and axes. Lower marks should be given to a pilot who used only one or two principal axes of flight. However, the use additional axes within the performance zone

must be clear and precise, not giving the appearance of being used by chance.

Marks should also be deducted if any particular maneuver element is overused or continues for an excessive period of time. For example, higher marks would be given in the event of a two-turn flat spin followed by something else, than to a multi-turn spin that simply took up more time.

B. Artistic Impression {90 K}

b.1. Pleasing and Continuous Flow of Figures with Contrasting periods of Dynamic and Graceful Maneuvers (50 K). In a precisely flown sequence, the completion of a figure will be well described when movement about an axis ceases and a particular attitude is briefly held. The start of the next figure or maneuver should then begin without any prolonged period of inactivity caused by the need to reposition the aircraft or reorient the pilot. Marks will be deducted for any obvious period of level flight, or inactivity, required between figures.

In a musical symphony, the listener’s mood may be changed by contrasting fast and slow movements. Similarly, in a 4-minute Free Program, the judge should be treated to a flight that causes different reactions. While some maneuvers involve very high speeds, sudden attitude changes and rapid rotations, others involve slower speeds or more gentle transitions. Higher marks will be given to a pilot to finds time in his program for showing such differences of mood and pace. Marks should be deducted in this category for a flight that shows no such distinctions.

Higher marks should be given for choreography with the music to enhance the flight, and the flight choreographed to enhance and present visual impressions where both the music and aircraft are flowing together with each other and acting as a unified entity to display a harmonious presentation.

b.2. Presentation of Individual and Combinations of Figures in Their Best Orientation and Optimal Position (40 K). Figures can give different impressions when seen from different viewpoints. For example, a climbing inverted flat spin looks most impressive when the top surface of the aircraft can be seen. A loop flown in a plane inclined at 45 degrees to the vertical is best appreciated when it is flown on the Y-axis. Marks should therefore be deducted if the judge is not shown a figure in its best orientation.

Each figure has an optimum from which it is best viewed. For example, a loop flown

overhead does not give the same pleasing geometry as one flown further distant. Similarly, a figure flown near the upper height limit will cause discomfort when flown at the near edge of the performance zone; a low-level horizontal figure is better seen from close by than far away. Higher marks will therefore be given when individual figures are optimally placed, while judges should deduct marks when it appears that a figure is not well placed or positioned.

C. Positioning {20 K}

c.1. Symmetry of the Presentation

Utilizing the Performance Zone to Maximize the Audience and Judges Perception, Reception, and Viewing of the Program (20 K). Highest marks will be given when the sequence as a whole is balanced evenly to the left and right of the judges; direct line of vision towards the center of the performance zone. Marks should be deducted if, by design or by the influence of the wind, a pilot's program is noticeable biased to left or right.

The greater the degree of symmetrical, it may also be spread too far to either side, so that some maneuver elements are flown outside the performance zone, thus making them difficult to see and interpret. Figures may also be flown on the direct line of vision but very distant. Any part of the flight that is flown at such distances should be penalized for each excursion. The entire program should be positioned so as to maximize both the audience and judges perception and reception of the flight as a whole.

17.2. Judging the Four (4) Minute Free Program.

a. Any number of judges can be utilized. As more judges that are used, the overall score average will be less influenced by a single judge. It is recommended that seven (7) be used. For final score tabulation it is recommended that the high and low score per judging criteria category be discarded, and the remaining scores be multiplied by their K factors and added together to obtain the final score.

b. Each criteria will be judged from ten (10) to zero (0) in 0.1 increments, i.e., 8.7, 7.9, 9.8m etc.

c. If the pilot lands any time prior to 3 minutes 30 seconds (three and one-half minutes) the judges score is "prorated." Example: the pilot lands at the three (3) minute time. The judges will score the contestant as through he flew four minutes. The score room will tabulate the scores normally and the pilot will receive three-fourths (75%) of the judges score for his final score. If the pilot lands any

time after three and one-half minutes there is no penalty. The judges will stop scoring when the timer announces "Time" at the four minute mark. Another Example: If the pilot lands at the two minute mark, he will receive 50% of the judges score.

d. Specific circumstances that will Disqualify (DQ) the competitor's flight.

d.1. If the plane crashes, it is a Disqualification (DQ).

d.2. If the plane goes behind the deadline, it is a DQ.

d.3. If the pilot performs dangerous or unsafe maneuvers or high energy maneuvers directed at the judges or spectators, it is a DQ. (As determined by a majority of the judges and/or the CD).

SCALE AEROBATICS OFFICIAL FLYING AND JUDGING GUIDE

The current Scale Aerobatics Contest Director's Guide is available from the International Miniature Aerobatics Club (IMAC) secretary, or may be downloaded from the IMAC Web site, <http://www.mini-iac.com>.

• 1. Preface. The purpose of this Scale Aerobatics Flying and Judging Guide is to provide an accurate description of each type of maneuver used in competition and to provide a reference for use in developing a uniformly high standard of judging in all AMA sanctioned contests. Study of this guide by the competitor will help him or her learn exactly what is expected, while study by the judges will help them decide precisely how well the competitor meets these expectations.

Flying and judging are very similar in nature; this is why contestant judging is generally promoted. Nevertheless, there are some key differences between judges and pilots, mostly related to Mental Attitude and Technical Knowledge. Reference to any gender in this document shall include both male and female.

1.1. Mental attitude. Mental attitude by itself can be divided into four (4) sub-categories:

1.1.1. Bias. Bias can either be conscious or unconscious. The conscious bias is fortunately rare, and would be for instance when a judge deliberately awards a score lower or higher than the competitor deserves. The word for that action is cheating and it shall not be tolerated.

Conscious bias can also occur because a friendship or regional relationship with the competitor. Most problems with bias are of the unconscious or unintentional type since they are more prevalent. A good example would be the

'halo' or recognition for a champion or well-known flier who might unintentionally be awarded extra points based on recognition alone. This can work against an unknown flier having a great day. This type of bias can also work against the champion flier, just because the judge unconsciously might want to see a new face in the winner circle. Another example might be bias towards a certain type of airplane like mono versus biplane, or bias towards a style of flying. For instance, a pilot cuts crisp corners on square maneuvers versus a flier with a more graceful style. Sometimes we even see an equipment bias where a judge may unknowingly try to support a previous personal opinion regarding a certain brand of radio, certain type of engine, or size of aircraft. These unconscious biases are easily understood as we all have personal preferences. Nevertheless, the judge must try hard to base his or her score solely on the quality of the flight, and nothing more.

1.1.2. Self-confidence. The self-confidence factor is based on knowledge instead of arrogance or ego. A judge with self-confidence can score a pilot fairly, whether he is a World Champion or not. A judge with self-confidence will not be uncomfortable in giving a wide range of scores in a single sequence. Scores as low as 2 or 4, or as high as 9 or 10 will not be uncommon.

1.1.3. Sense of independence. A judge doesn't operate in a glass cage but shares the flightline with another judge and scribes. The judge cannot allow himself or herself to be influenced by more dominant or experienced personalities sitting nearby. Judging is an independent exercise and caution should be exercised not to influence or be influenced by others on the flightline. If scribes are used, scores should be communicated using a low tone voice so that the other judge and the pilot cannot hear and be influenced by it.

1.1.4. Adherence to the rules. Adherence to the rules is probably the most significant of all the elements required to make a good judge. A good judge has developed a sense of fair playing and knows that a good contest is one in which everyone plays by the same rules. Anyone sitting in a judging chair must adhere to the rules existing at that time or disqualify him or herself.

1.1.5. Technical knowledge. Technical knowledge employs the use of an organized system of downgrading as well as the need to be

consistent and accurate. The downgrading or deficit grading system assumes that the contestant is going to fly a perfect maneuver that starts with a 10, and then downgrades it based on the mistakes observed as they occur, rather than falling into the trap of scoring on overall impression. It should be assumed by a judge that a contestant is going to fly a well-formed maneuver, so he should start with the grade of 10. As he watches the maneuver, he then begins to find fault with what he sees and starts downgrading as it progresses. This system is preferable to waiting until the maneuver is finished, and try to assign a grade on overall impression. The later can be erratic and inconsistent, and also confines grading into a too narrow range. However, as a final check, the score should be consistent with the figure's overall quality.

Every judge should strive for a high degree of consistency and accuracy. The most important aspect of consistent judging is for each judge to establish his or her standard and then maintain that standard throughout the contest.

• 2. FAI Aresti System (Condensed). Scale Aerobatics sequences are based on a catalog of maneuvers defined by the FAI (Fédération Aéronautique Internationale) for full-scale aircraft aerobatics. The catalog consists

- i. Family 1 - Lines and Angles
- ii. Family 2 - Turns and Rolling Turns
- iii. Family 3 - Combinations of Lines
- iv. Family 4 - (Not in Use)
- v. Family 5 - Stall Turns (Hammerheads)
- vi. Family 6 - Tailslides
- vii. Family 7 - Loops & Eights
- viii. Family 8 - Combinations of Lines, Angles and Loops
- ix. Family 9 - Rolls and Spins

of the following nine (9) families of figures:

It is beyond the scope of this Flying and Judging Guide to explain in detail the structure of the FAI catalog, and how to read the Aresti

Rules	Scale Aerobatics	IAC	Pattern
Downgrade one (1) point for each deviation of:	10 degrees	5 degrees	15 degrees
Judging criteria:	Flight path	Aircraft attitude	Flight path
Number of judges	2 minimum	5 standard 3 minimum	2 minimum

drawing language used. A good judge (as well as a pilot) must become very familiar with the above and should be able to quickly understand the maneuver simply by looking at the Aresti drawing. The complete catalog of figures is available directly from the FAI Web site at (<http://www.fai.org/aerobatics/catalog/>). Judges and pilots are strongly encouraged to download this document for personal reference.

3. Rules. Scale Aerobatics has several rules that differ from either Full Scale Aerobatics (IAC) or AMA RC Aerobatics (AMA Pattern). Because the judging pool used in Scale Aerobatics contests sometimes comes from both or either of those two groups, it is useful to go through the major differences:

- 4. Aerobatic Airspace.
- 4.1.X-Axis and Y-Axis

The X-Axis is the main axis of flight, parallel to the flight line. The Y-Axis is perpendicular to the X-Axis (flight line).

4.2 Deadline.

The “Deadline” is located 100 feet (30.5 meters) in front of the contestant. This line delimits the “no-fly” zone for safety reasons. The judges shall zero (0) any maneuver where the aircraft completely crosses this deadline.

4.3 Airspace Control Score

Judges will evaluate each individual sequence flown, in its entirety, for overall airspace control. Each judged Known and Unknown sequence, shall have one “figure” added to the end of the score sheet, after individually judged maneuvers. This figure shall be known as the *Airspace Control Score* and will be assigned by each judge. The Airspace Control Score will have a K value dependent on the class flown. This score will then be multiplied by the K Value for the individual class.

The following standard will be used for accessing the pilot’s performance in maintaining control and awareness of the aerobatic airspace and placing figures in the airspace in a manner that allow the figures to be optimally judged. The highest standard for Airspace Control will be the pilot that exhibits a significant ability to control the location of the aircraft inside the

airspace, relative to the judges, which results in a tight footprint and has the aircraft such that it can be optimally judged at all times. The pilot that exhibits excellent airspace control should receive a ten (10).

The lowest standard for Airspace Control will be the pilot that exhibits a poor ability to control the location of the aircraft inside the airspace, relative to the judges, which results in an excessively large footprint and has the aircraft consistently so far away as to be difficult to properly judge. The pilot that exhibits very poor airspace control should receive a zero (0). Pilots exhibiting airspace control within the range of these two standards will be graded with a range of possible scores from ten (10) to zero (0) in whole point increments.

The K factors for the Airspace Control Score are:

Basic = 3K

Sportsman = 6K

Intermediate = 9K

Advanced = 12K

Unlimited = 15K

5. Flight Path, Aircraft Attitude, and Wind Correction. Scale Aerobatics requires all maneuvers within the sequence to be wind corrected. See Rule 5.3.

Judges should evaluate any maneuver focusing primarily on the aircraft flight path, but at the same time, also downgrade for any variation of the aircraft attitude that is not directly related to maintaining a correct flight path.

5.1. Flight path. Think of the aircraft

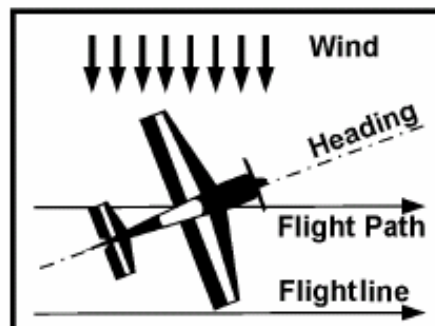

Fig. 2

Cross winds will force the aircraft to 'crab' or change its attitude in order to maintain a flight path parallel to the flightline.

condensed into a single dot and watch the path this dot takes through the sky. This is the flight path, or track, or the aircraft's center of gravity. Judging the flight path consists of comparing the observed path with fixed references such as the horizon, or the X and Y-axis of the aerobatic airspace

5.2. Attitude. The aircraft attitude is defined as the position of the aircraft in the sky, and is characterized by the variations it has on the yaw, pitch, and roll axis. In a "no-wind" and normal speed condition, the aircraft's attitude (its heading) will generally point in the same direction as the flight path. In case of a cross wind, the aircraft attitude must vary (on the yaw axis) in order to maintain a constant and straight flight path, as required by the Scale Aerobatics rules (Fig. 2).

Also, a reduction in speed will force the aircraft to change its pitch in order to maintain the correct flight path (Fig. 3).

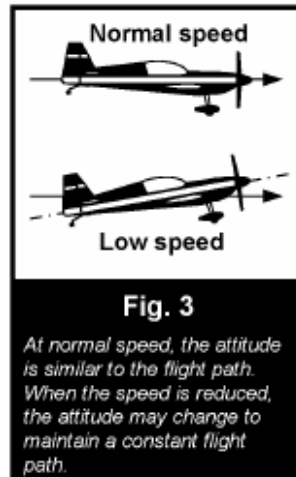

Depending the type of aircraft (low wing, high wing, etc.), the flight attitude might be different from one to another to maintain the correct flight path. Judges should disregard this difference in attitude and only concentrate on the flight path described by the aircraft.

5.3. Wind correction. When judging a maneuver, understanding what constitutes wind correction, and what is not, is one of the toughest challenges. The general rule is that judges should ignore any aircraft change of attitude required to maintain a correct flight path. At the same time, the usual 0.5 point deduction per 5

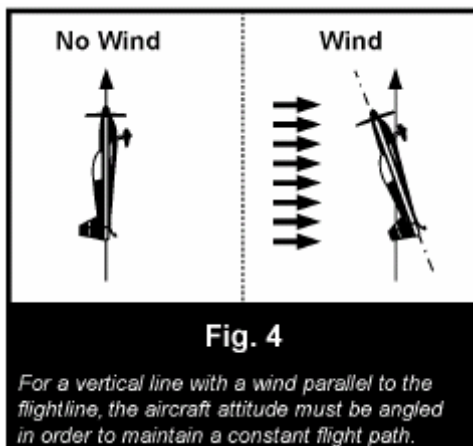

degrees of deviation shall be applied to anything that is not related with wind correcting. For instance, when the wind is blowing parallel to the flight path, the pilot flying a vertical line might use its elevator to change the aircraft's attitude in order to maintain a straight vertical flight path (Fig. 4).

This change of attitude should not be

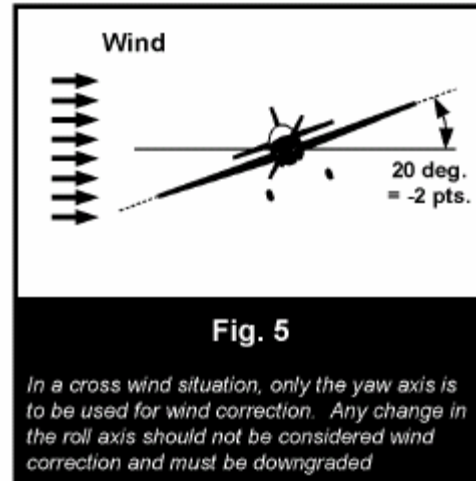

downgraded. On the other hand, any bank angle of the wing in the roll axis should be downgraded using the standard rule of 0.5 point

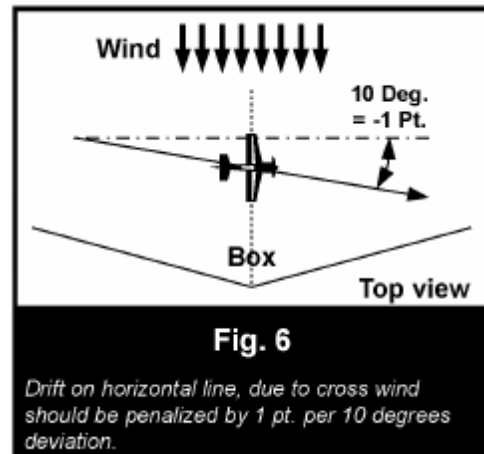

deduction per 5 degrees (Fig. 5). The judges should only downgrade for induced pilot corrections and disregard any sudden attitude changes due to wind bumps. Always give the competitor the benefit of the doubt when not sure.

The only maneuvers that are not to be wind corrected are the ones involving a stalled condition, such as a hammerhead, tailslide, spin and snap roll(s). During the period of time that the aircraft is in a stalled, or near stalled

condition, any wind drift should be disregarded by the judges and not downgraded.

Wind correction should be used throughout the aerobatic airspace. Any drift observed on any line (horizontal, 45 degrees or vertical) should be downgraded using the 0.5 point deduction per 5 degrees rule (Fig. 6). For instance, in the case of a hammerhead performed with a severe crosswind, the vertical line will start directly after the ¼ loop. This is the first point of reference to be used for the upline. The flight path on the way up is 15 degrees off compared to the perfect vertical up line; the downgrade should then be 1.5 points. When the aircraft starts its hammerhead, it is in a stalled condition and no downgrade should be applied for wind drift during that time. Once the rotation is complete, a new reference point should be established for the perfect vertical downline. If the flight path on the downline is 20 degrees off, the downgrade should then be 2 points (Fig. 7). The competitor is required to make the shape of all maneuvers perfect regardless of the wind conditions. Loops and partial loops must be round, vertical lines must be perpendicular to the horizon and horizontal line parallel to the X or Y-axis. For 45-degree lines, judges must make an allowance for the aircraft's position relative to their own. A true 45 degree line flown at the end of the aerobatic airspace will appear steeper when flown towards the end of the airspace and shallow when flown towards the center. Judging is of the true line flown and judges should not downgrade the maneuver for visual deformation due to the angle it is observed. Always give the competitor the benefit of the doubt when not sure.

6. Grading of Figures. The judges will independently assess the quality of each figure and its components as performed in the sequences, grading with numbers from ten (10) to zero (0) in increments of

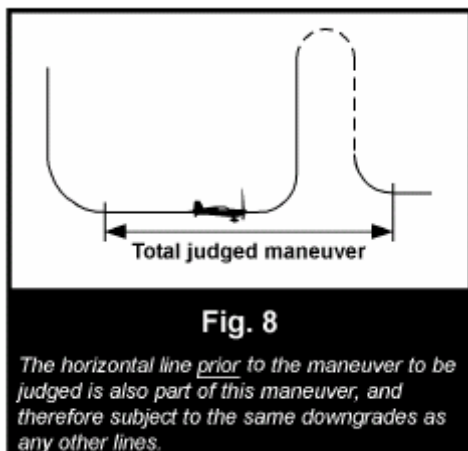

one-half (1/2) point. A grade of ten (10) represents a perfect figure in which the judge saw no deviations from prescribed criteria.

Remember, it is the judge's job to find fault: be a nitpicker. On the other hand, give a grade of 10 if you see a perfect figure—but if you are really being critical, you won't see too many. Don't get in a rut. Guard against confining your grades in too narrow a range. If you watch carefully and grade consistently, you will find yourself giving an occasional 2, 3, or 4 on some sloppy figures that are not quite bad enough for a zero. You will also be giving an occasional 9 or 10 for the superlative figure which you can find little or no fault.

As a judge, you are expected to grade

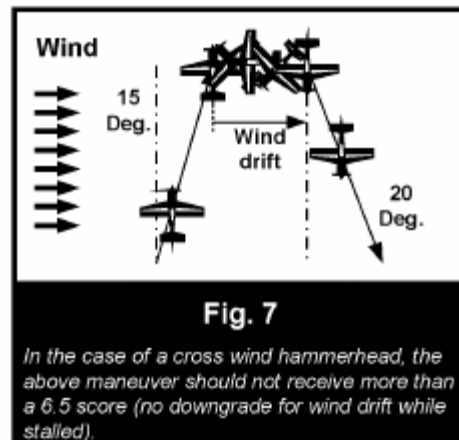

only against one standard, and that is perfection. The performance of the aircraft, the difficulty in performing a figure (on the basis of your personal experience or perception), the weather condition or the pilot's name and reputation should not be considered in formulating your grade.

Two (2) judges should be used to judge each sequence. There should be enough judges available to establish a rotational procedure that will average out variations in judging. Sets of judges shall judge all contestants an equal number of times and all contestants shall have an equal opportunity to fly before all judges. Substitution of judges, which precludes equal exposure by all contestants, shall be avoided. If adverse weather conditions preclude equal exposure for all contestants, the results of the sequence may be disregarded at the discretion of the Contest Director.

6.1. Grading principles. When grading the quality of the performance of individual figures, judges should consider the following general principles:

a) The geometry of the figures (including the shape, radii, angles, flight path, direction of flight, heading and bank angle) must comply with the prescribed criteria.

b) The precision of the performance compared to the criteria as explained later in this guide.

c) The smoothness of the performance

d) The distinctly recognizable start and finish of each figure with a horizontal line.

e) The figure must be the one depicted on the flimsy (Form B or C) appropriate to the direction of the flight chosen by the pilot to perform and flown in its proper order within the sequence. For figures with a Y-axis component, it is the pilot's discretion, in addition to fly inbound or out bound, as to which direction to fly the turn, left or right. For Family 9, Rotational Elements it is the pilot's discretions to which direction to perform the roll or first roll, if it is unlinked roll combination. In all cases, the figure flown must have the entry and exit direction as depicted on the flimsy appropriate to the direction of flight chosen by the pilot to perform (Form B or C) in the X-axis.

f) The grading criteria of each component will apply in a combination figure so that one overall grade for the figure will result.

g) The length of the lines and the size of the radii caused by the flying characteristics of an aircraft are not to be taken into account in the grading.

h) Negative figures are graded by the same criteria as positive figures.

i) Speed of aircraft is not a criterion. A reduction of grade will be applied for each deviation from the prescribed criteria for the figure. The grade will be reduced by 0.5 points for each 5 degrees of deviation.

6.2. Beginning and ending of a figure.

The first figure of a sequence begins at the moment the aircraft departs from its wings-level, horizontal flight path.

A figure is complete at the moment the aircraft returns to a wings-level, horizontal flight path. The only exception to this is the exit lines in FAI "Aresti System Condensed", Families 7.7 and 7.8 (Square Loops). Once a horizontal flight path is established at the end of a figure, the

beginning of the next figure is deemed to have occurred (Fig. 8). If an aircraft does not return to wings-level, horizontal flight before commencing the next figures the one (1) point per figure deduction will be applied. Ref. Rule 7.1

If the competitor corrects any errors in exit flight path, bank angle, or heading before initiating the subsequent figure, only the first figure shall be downgraded. Failure to correct such errors shall result in a downgrade to both figures.

• 6.3. Zero. A zero will be given for:

a) Omitting a figure in the program. In this case, only the omitted figure will be zeroed. For instance, if the pilot omits the center maneuver and flies straight to do the end box maneuver, only the center maneuver will receive a zero and the end box maneuver will be scored normally.

b) Flying a figure that deviates from the Aresti drawing held by the judges for scoring purposes. For instance, if the pilot flies a Humpty Bump instead of a Hammerhead, the maneuver will be zeroed.

c) Adding a figure to a program will zero the next following correct figure except when it is necessary to reposition the aircraft direction or attitude due to the previous maneuver not being completed as per the program. The correction maneuver can only be a turn of 270 degrees or less and a roll of no more than 180 degrees. In this case, a break penalty will be assessed against the competitor's raw score prior to normalizing. A zero will be given to the figure immediately following any other added figure, even if the following figure is performed correctly.

For instance:

i. If the exit of a maneuver is done upright instead of inverted (the pilot forgot to perform a ½ roll on the downline), and corrects this by doing ½ roll immediately after the exit, on the horizontal line, the original maneuver will be zeroed because the ½ roll was omitted on the downline, however the following maneuver will be scored because this ½ roll was added only to correct the attitude of the aircraft for the beginning of that next maneuver. (Fig. 9). A break penalty will be applied, see Rule 6.3 (d).

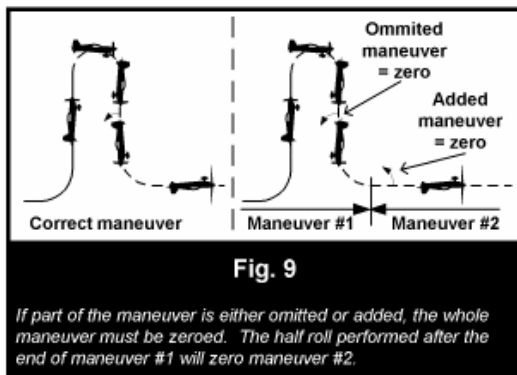

ii. If the pilot exits the maneuver in the wrong direction on the X-axis (pull instead of push at the bottom of a figure), then adds a 180 degree turn and a 180 degree roll to correct the mistake and comes back to the correct flight direction he/she will be assessed a break penalty, see Rule 6.3 (d). The original maneuver will be zeroed because the exit ¼ loop was not performed per the Aresti, and the following maneuver will be scored from wings level after the completion of the 180-degree turn.

d) Break in the sequence. A break in the sequence is characterized by a total departure from the sequence to be flown. For instance, a pilot that becomes disoriented aborts the maneuver and circles around a couple times before resuming the sequence again. Another example might be a pilot that aborts a maneuver thinking that the aircraft has equipment problems, makes a couple of fly-bys in order to confirm that everything is operating normal, and then decides to resume the sequence. A “deadstick” or a landing during the sequence shall not be considered as a break and all remaining maneuvers that were not flown will be zeroed.

Break Penalties	
(deducted from average raw scores prior to normalization)	
Basic	10 pts
Sportsman	20 pts
Intermediate	40 pts
Advanced	70 pts
Unlimited	100 pts

When the break occurs, the maneuver in progress might be scored if the pilot doesn't omit anything and is able to establish a wings-level horizontal flight before breaking the sequence. If the break occurs at any time during the figure, or even during the horizontal line before the wings depart from their horizontal level attitude, only

the figure in progress should be zeroed, but not the following prescribed maneuver.

The pilot or the caller should verbally indicate to the judges his intention to resume the sequence. He should then first establish a wing-level horizontal line, call the restart of the sequence to get the judges' attention, perform the last maneuver that is to be zeroed and continue the sequence from there on. Normal judging will resume after the completion of the zeroed.

A break in the sequence related to safety, weather, for collision avoidance or by request from the judges or the Contest Director should not be penalized.

e) Flying a figure in the wrong direction on the X-axis. The Y-axis is

non-directional.

f) Any cumulative deviation in excess of 90 degrees in the roll, pitch or yaw axes that are not related to wind corrections.

g) Any figure or figures started and flown completely outside the Aerobatic Airspace.

h) Any figure started or flown even partially behind the dead line. The aircraft must clearly infringe dead line to receive a zero. Judges should not communicate to each other during the judging of the sequence, and score each figure independently. Once the sequence is complete, the judges may confer and review any figure receiving a zero but need not agree on the score.

If a judge misses one or more figure, or any part of a figure such that a grade cannot be given with full confidence, the judge should then leave the score sheet space(s) empty until the sequence is complete. He/she should then confer with the other judge and use his score for the missing figure(s). If both (or all) judges, for any reason, are not able to grade a figure with full confidence, they can ask the pilot to re-fly the missed figure beginning with the figure prior to the missed figure. Only the missed figure will be scored in this case.

7. Basic Components of Aerobatics.

7.1. Lines. All lines are judged in relation to the true horizon and the axes of the Aerobatic Airspace. Horizontal and Vertical lines are judged primarily on flight path (Ref Rule 5.3 for wind correction criteria).

All figures begin and end on definite horizontal lines, and both must be present in order to earn a good grade. A competitor who rushes from one figure to another, without showing this horizontal and well-recognizable

line will be downgraded by one (1) point for each missing line in each figure affected. Therefore, leaving out the line between two figures will downgrade the preceding figure by one (1) point and the following figure also by one (1) point. (Fig. 11).

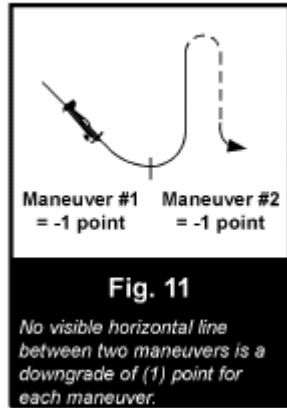

All lines that occur inside a figure have a beginning and an end that define their length. They are preceded and followed by part-loops.

With the exception of Family 3 figures (Combination of Lines) and some figures in Family 7 (loops and Eight's), the criterion for the length of lines within a figure states that they do not have to be of equal length (Fig. 12).

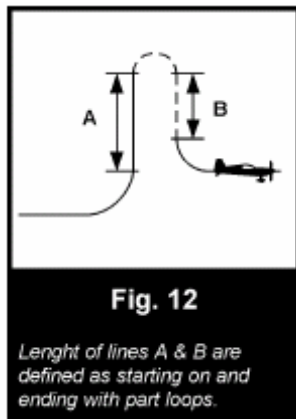

For example, the length of the lines in a "Humpty-bump" do not need to be equal, but all four lines in a "Square Loop" must be of equal

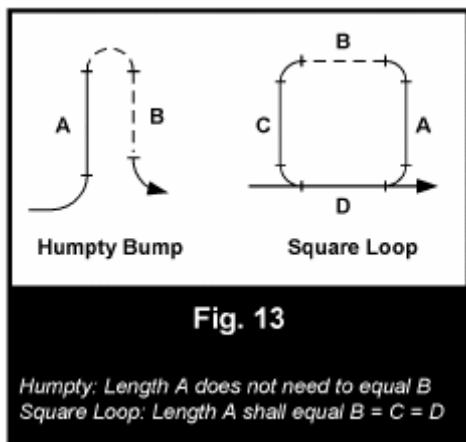

length (Fig. 13).

Whenever any kind of roll is placed on an interior line, the lengths of the two parts of the line before and after the roll must be equal. Exceptions are when any type of roll follows a spin element. Judges should take care to judge the symmetry of the length of lines in a figure using only the length of the lines and not be elapsed time taken to fly each segment. This difference in length versus elapsed time is most noticeable in figures where rolls are placed on up-lines. As the aircraft loses airspeed, the time it takes to fly a line after the roll will be greater than the time required to fly the line of the same length before the roll.

If within a figure two or more lines must be of the same length, an observed variation is penalized by reducing the grade in the following manner (Fig. 14):

- i. A visible variation = 1 point deduction
- ii. If the lengths vary by 1:2 = 2 point deduction
- iii. And so forth up to a 3 point deduction
- iv. No line before or after roll, 4 point deduction.
- v. No line at all before and after roll = 2 point deduction.

The basis for judging line length is the first line flown. The absence of one of these lines either before OR after a roll has to be penalized by one

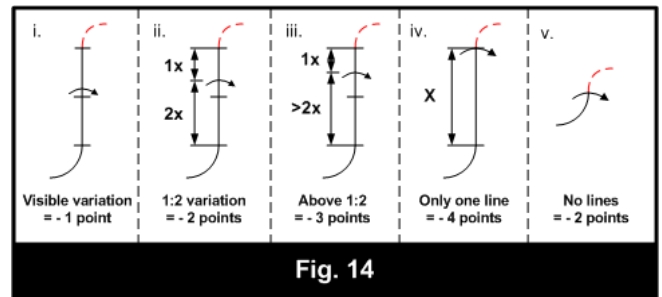

(1) additional point. IF there are no lines before AND after the roll, the total penalty is two (2) points only.

Example: The competitor is to fly a vertical up-line with a full roll on the line. However, the aircraft is returned to level flight immediately after the roll. The deduction is 4 points: 3 points are deducted because the lines are of vastly different length and another 1 point is deducted because of the absence of one of the lines.

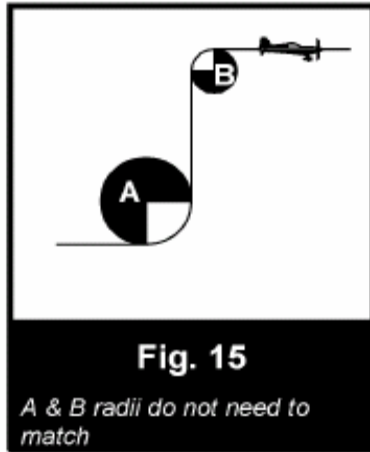

7.2. Loops and part-loops. The loop is a figure from Family 7, but part-loops are integral to every other family so it is necessary to discuss the loop before going on to the other families.

A loop must have, by definition, a constant radius. It starts and ends in a well-defined line that, for a complete loop, will be horizontal. For a part-loop however, such lines may be in any other plane of flight. As the speed changes during execution of a loop or part-loop, the angular velocity around the aircraft's lateral axis also has to change in order to keep the radius constant. When the speed decreases, for example, to half its initial rate, the angular velocity, to keep the same radius, will be reduced by half—this is a fact of physics. Thus, the angular velocity can be an aid for the judge to gauge the radius—especially when the angular velocity in the higher part-loop is seen to be faster, as this is a clear indication that the radius is smaller. This aid becomes more important when a line separates two part-loops.

The part-loop of any one figure should all have the same radius, except in Family 1 (Lines and Angles) and where indicated in Family 8.1 through 8.28 and 8.49 through 8.56. For example, a figure starts on a horizontal line, with a quarter loop next, followed by a vertical line and then another quarter loop. The quarterloop at the top of the vertical line (Family 1 figure) need not have the same size radius as the quarter-loop at the bottom (Fig. 15). However, the top radius must not be “corner” or very sharp angle (Fig. 16). It must have a smooth, distinct, and constant radius.

8. FAI “Aresti System (Condensed)” Families.

8.1. Family 1: Lines and Angles. Family 1.1 to 1.11 has been fully covered in the preceding section. Note that the figures in Family 1.12 to

1.19 are NOT performed as drawn in the FAI “Aresti System (Condensed)”. In each of these figures there are three looping components: a one-eighth loop, a three-eighth loop and a quarter loop. Rolls may be performed on the 45-degree line and/or the 90-degree line, with the part line being of equal length. The initial horizontal line and the line at the end of the figure may be flown at a different altitudes (Fig. 17).

8.2. Family 2: Turns and Rolling Turns.

8.2.1. Turns. In aerobatic competition, a turn is divided into three parts:

- 1) Establishing the bank using a roll on heading.
- 2) The turn itself.

3) A roll back to straight and level flight on heading.

Let's look at the turn during each of these three parts. First, the roll to establish the bank. This must be a roll of between 60 and 90 degrees; it must be performed on the entry heading; and the aircraft must maintain a constant horizontal line. Once the roll is completed and the angle of bank is established, the competitor immediately

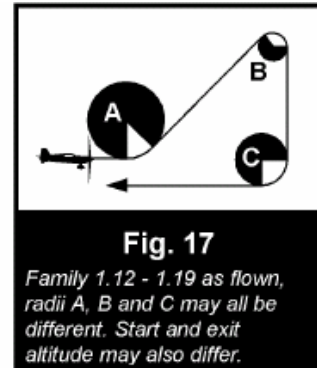
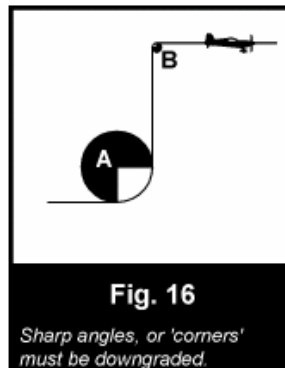

performs the turn. The turn must maintain the established angle of bank throughout. The aircraft must also maintain horizontal flight. The rate of turn is constant throughout and the maneuver must be wind corrected so that, for instance, a 360-degree turn will be a perfect circle. It

should be noted that the wind correction cannot be performed by visibly changing the bank angle.

As soon as the aircraft is on the exit heading, the competitor performs another roll at a rate equal to the entry roll. Again, the aircraft must maintain a constant horizontal line.

Downgrades:

- a. The angle of bank established by the initial rolling maneuver must be at least 60 degrees and not greater than 90

degrees. Any less or more is a 0.5 point deduction for every 5 degrees.

b. The angle of bank, once established, must remain constant. Any deviation is a 0.5 point deduction for every 5 degrees of deviation.

c. The rate of roll must be the same for the entry and exit rolls of this figure. Any deviation is a one (1) point deduction.

d. The aircraft must maintain a constant altitude throughout the figure. Any variation would be 0.5 point deduction for every 5 degrees of change.

e. The rate of turn must remain constant. Any change would be not more than a one (1) point deduction for each change. Note that the rate of turn may appear to change in a strong wind, when it really isn't changing. The judges must always keep the wind in mind and give the pilot the benefit of the doubt if there is any question.

f. The aircraft must begin and end of the prescribed heading. Any deviation is a 0.5 point deduction for every 5 degrees of deviation.

8.2.2. Rolling Turns. The rolling turn is a figure that combines a turn of a prescribed amount with a roll or rolls integrated throughout the turn.

These rolls may be in the same direction as the turn and are called "rolls to the inside" or may be in the opposite direction of the turn and are then called "rolls to the outside" (Fig. 18). There can also be rolls alternating in and out.

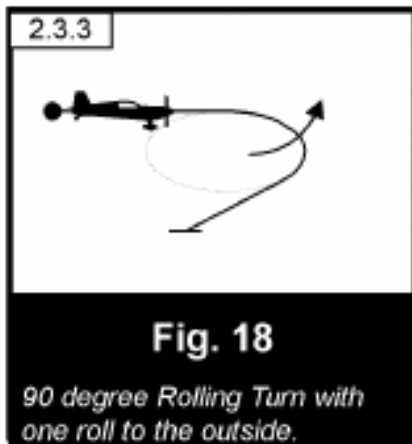

When we say that the rolls are integrated, we are saying that in addition to there being constant rate of turn throughout the figure, there is also a constant rate of roll throughout. Naturally, the

one exception to this constant roll rate is the pause when reversing roll direction.

To help visualize the execution of this figure and facilitate a way for the judges to determine a constant roll rate, let's look at an aircraft performing a 360 degree rolling turn with 4 rolls to the inside from upright (Family 2.10.1). First, on the prescribed entry heading, the pilot executes a turn and simultaneously initiates a roll in the same direction as the turn. The judges will expect the aircraft to be inverted at 45, 135, 225 and 315 degrees and to be upright at 90, 180, 270 and 360 degrees. At these interim headings, the judge will NOT downgrade using the 0.5 point for 5 degree rule but will judge changes in the rate of roll, changes in the rate of turn and changes in altitude. At the end of the 4 rolls, the aircraft must have terminated its 360 degree turn and finish at the same point where it started, wings level and on the prescribed heading. When a rolling turn is performed with rolls alternating directions, the aircraft must change direction of roll at a wings level attitude. The position of the aircraft in the turn is still only used as an aid to determine if the pilot is varying the rate of roll or turn.

Downgrades:

a. Performing more or fewer rolls than the catalog description calls for results in the figure being zeroed.

b. All rolls in a rolling turn are standard rolls. If a snap roll is performed, the figure is zeroed.

c. Each stoppage of the rate of roll is a deduction of no more than one (1) point.

d. Each variation in the rate of roll is no more than a one (1) point deduction.

e. Each variation in the rate of turn is no more than a one (1) point deduction.

f. Variations in altitude are deducted using 0.5 points per every 5 degrees difference.

g. 0.5 points per every 5 degrees that the aircraft is not in level flight when reversing roll direction.

h. 0.5 points for every 5 degrees of roll remaining when the aircraft has reached its heading.

i. 0.5 points for every 5 degrees of turn remaining when the aircraft has completed its last roll.

8.3. Family 3: Combinations of Lines. The transition from level flight to a 45-degree line should be at a constant and reasonable 1/8 looping radius. All lines within the figure should

be equal in length. The 45-degree transitions in Family 3.1 should have a constant radius and not a sharp corner (Fig. 19).

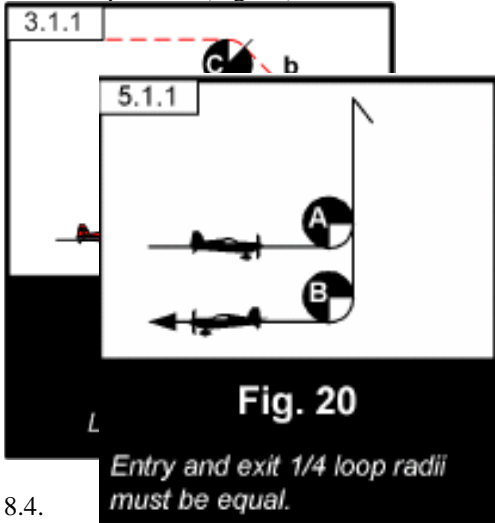

8.4. Family 4: Spins (Spins are now part of Family 9).

8.5. Family 5: Hammerheads.

Hammerheads, also referred to as stall turns, are some of the most graceful figures in the FAI "Aresti System (Condensed)". In its most basic form, the figure begins when the aircraft leaves horizontal flight and flies a quarter loop to establish a vertical climb. At the top of the vertical line, the aircraft stops, pivots and establishes a vertical descent, with the figure ending as the aircraft is returned to horizontal flight.

The judging criteria are:

- a. The entry and exit quarter loop radii must be equal (Fig. 20).
- b. The vertical lines, both up & down, must be wind corrected so that they appear to the judge's eye as a straight line perpendicular to the horizon.
- c. Any deviation from the vertical line, either up or down, will result in a deduction of 0.5 points per 5 degrees.
- d. Any added roll(s) must be in the vertical climb or vertical descent and positioned so that the liens before and after the roll(s) are of equal length (Fig.

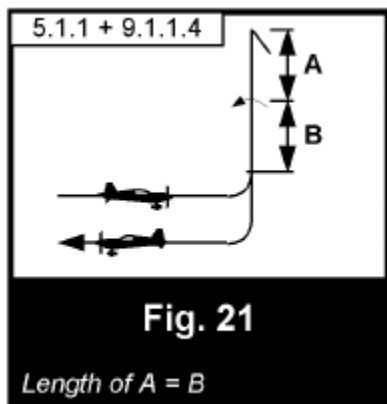

21).

e. The length of the vertical up and down lines need not be equal. As such, the altitude of the horizontal lines at the start and finish of the hammerhead may be different.

f. As the aircraft nears the point where it would stop climbing, it must pivot in a plane parallel to vertical.

g. When the aircraft pivots at the top of the line in a stall or near stalled condition, no deduction should be applied for wind drift during that particular time.

h. In the case of strong cross winds, the aircraft will most probably be "crabbing" to wind correct the up and down line. The pivot at the top of the line might therefore be less or more than 180 degrees and no downgrade should be applied to it.

i. Any pendulum movement observed after the pivot is subject to downgrade using the 0.5 points per degrees rule.

Ideally, the aircraft pivots around its center of gravity. To avoid a deduction, the aircraft must

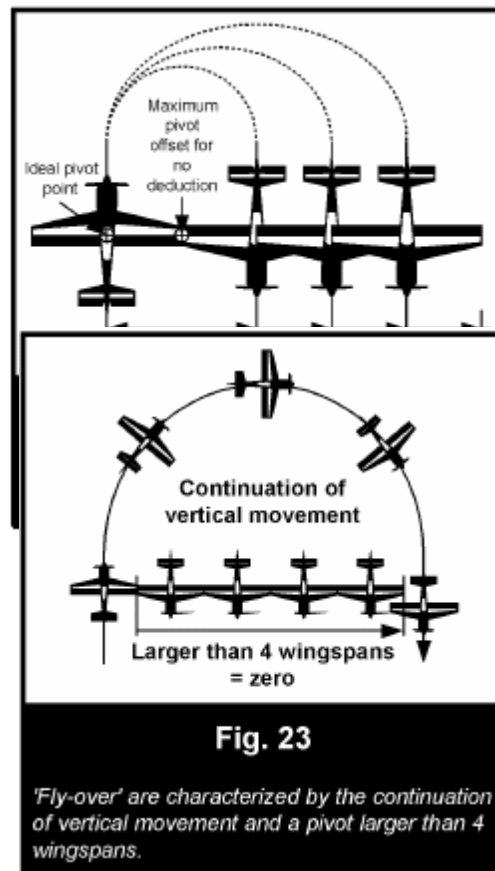

pivot around an axis point, which cannot be farther away from its center of gravity than its wingtips (1/2 wingspan). The downgrade for this deviation is one (1) point per half wingspan that the point of rotation exceeds the maximum allowed (Fig. 22).

Judges must be careful to deduct only for true extended turnaround, and not for any apparent deviation caused by wind drift during the pivot. One way to recognize a “fly-over” from a wind drift will be that they “fly-over” is generally characterized by the continuation of vertical movement and a pivot larger than 4 wingspans. A “fly-over” hammerhead should be zeroed (Fig 23). The maneuver should also be zeroed if any distinctive backward sliding movement is observed before the start of the pivot, even if the rotation is correctly performed

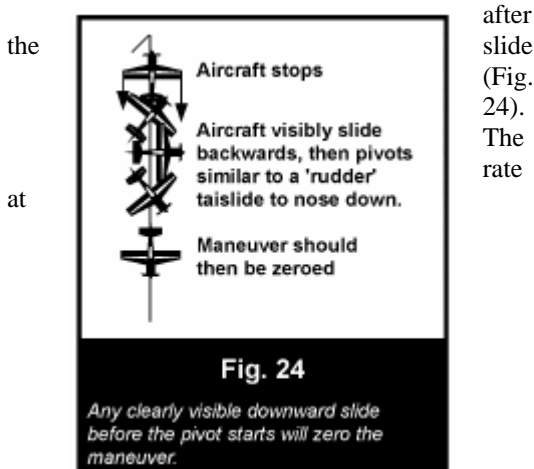

which the aircraft pivots around its vertical axis is not a judging criterion. The wings must remain in the vertical geometric plane throughout the turnaround, and the aircraft’s attitude before and after the turnaround must be absolutely vertical (unless wind correction is required), with no extraneous tail movement. There must be no rotation around the pitch or roll axis. If there is movement around any axis other than the yaw axis, often referred as “torquing” (Fig. 25), there is a deduction of 0.5 points per 5 degrees of axis.

- 8.6. Family 6: Tailslides. All the criteria of the Hammerhead apply to this figure except, of course, for the maneuver at the top of the vertical climb. At the point when the aircraft stops, it must slide backwards a visible amount in the vertical plane. The key here is “visible” and “vertical plane.” If the aircraft pivots directly on the top, without any clearly visible slide, the maneuver should then be zeroed (0). Following the slide backwards, the aircraft must then tip

over and fall through to a diving position. Often the nose will swing back or “pendulum” past the vertical after falling through. The figure is not to be downgraded for this, nor downgraded if it does not happen. It is a function of the length of the slide and the type of aircraft, and is not to be considered in grading the figure.

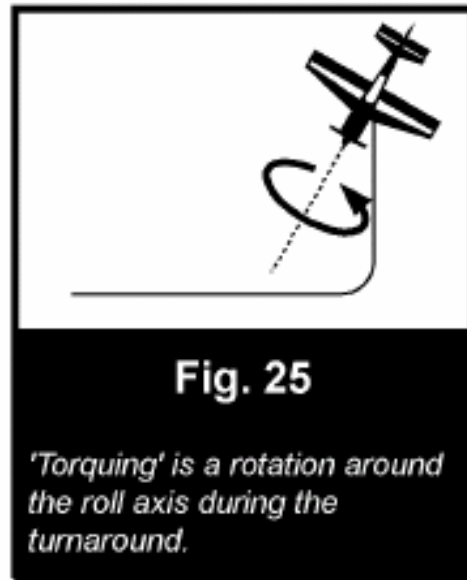

There are two types of Tailslides: wheelsdown and wheels-up. The wheels-down Tailslide is depicted in the Aresti diagram with a curved solid line at the top of the Tailslide symbol (Fig. 26). The wheels-up Tailslide is depicted in the Aresti diagram with a curved dashed line at the top of the Tailslide symbol (Fig. 27).

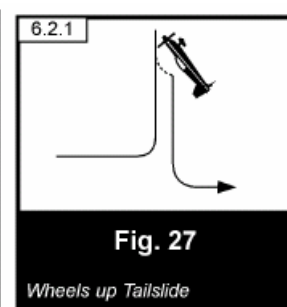
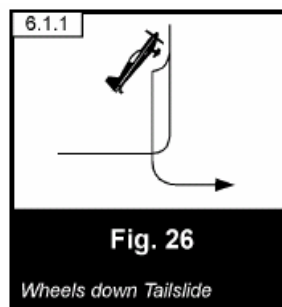

This figure must be watched carefully, as the aircraft can fall the wrong way (which is graded a zero) with the correct direction of flight and the proper aircraft attitude still maintained.

Wings should stay level with the horizon throughout and not drop during the slide or the fall through. Watch for the aircraft torquing off the correct plane of flight, which must be downgraded using the one (1) point per ten (10) degree rule.

As with the hammerhead, the aircraft will be in a stalled or near-stalled condition at the top of the vertical line and no deduction for wind drift should be applied during that particular time.

The entry quarter loop and the exit quarter loop must both have the same radii. The altitude of the entry and exit horizontal lines need not be the same and the figure must not be downgraded if they are different.

When rolls are combined with Family 6 figures, there must be an equal length of line before and after the roll(s). In the vertical downline, the aircraft must attain a vertical attitude and establish a downline before starting the roll(s).

In summary, the aircraft should make a smooth and steady transition up to vertical flight, and the aircraft should come to a complete stop in this attitude. After sliding backward a visible amount, it should fall through in the appropriate direction without dropping a wing or the nose moving off axis, and recover on the same plane as that of entry. After completion of this, it should again project the 90-degree downline (wind corrected if required) before transitioning into horizontal flight with a quarter loop of radius equal to the entry quarter loop.

8.7. Family 7: Loops, Vertical Ss, and Figure Eights. The size of a loop is not a grading criterion. It will vary according to the flight characteristics of the aircraft. A large loop is not graded any higher or lower than a small loop, but any variation to the radius will downgrade these figures.

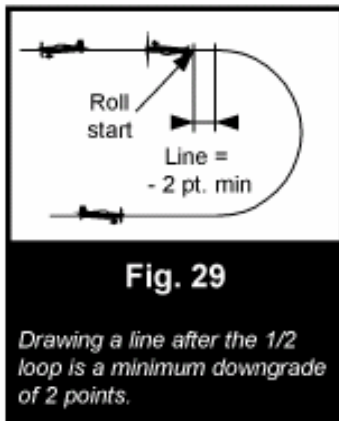

8.7.1. Family 7.1 - 7.4: Half loops with rolls. The half-loops in

this sub-family must be of a constant radius and wind-corrected to appear as a perfect half circle (see full loop discussion below).

When a half-loop is preceded by a roll or rolls, the half-loop follows immediately after the roll(s) without any visible line. Drawing a line requires a downgrade of at least two (2) points depending on the length of the line drawn. Should the half-loop begin before the roll is completed, the judge must downgrade the figure 0.5 points for every 5 degrees of half-loop flown on which the roll was performed.

The half-loop followed by a roll is also flown with no line between the half-loop and roll. Again, drawing a line requires a downgrade of at least 2 points depending on the length of the line drawn (Fig. 29). Should the roll begin before the half-loop is completed, the judges must downgrade the figure 0.5 points for every 5 degrees of half-loop on which the roll was performed (Fig. 30).

Great care should be taken here to differentiate between aircraft airfoils and the slow speed at the top of the half loop + roll maneuver. The aircraft will appear to begin the roll before reaching horizontal flight due to its high pitch attitude. As the aircraft accelerates, it will then establish a cruise pitch attitude.

8.7.2. Family 7.5 - 7.6: Full loops. All full loops must appear perfectly round to the judge (Fig. 31). If required, they must be wind corrected to have a constant radius. This wind correction is not only with regards to the roundness of the loop but also for the effect of any crosswind on the figure. Therefore, a standard deduction of .5 point per five (5) degrees should be applied if the finish point is displaced in a direction perpendicular to the plane of the loop (Fig. 32). In a heavy crosswind situation, a loop might be flown with visible crabbing and no deduction should be applied in this case.

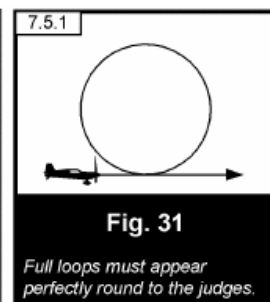
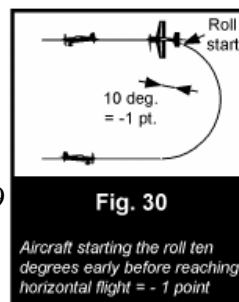

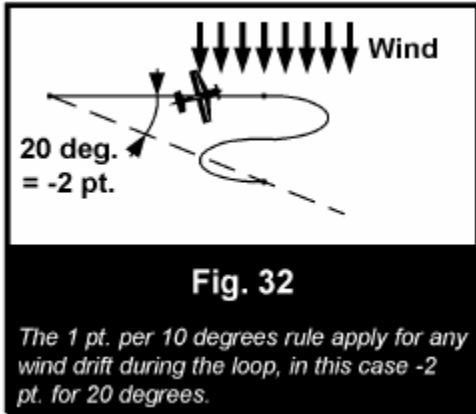

To better quantify deductions for loops, the judges should watch for these irregularities; perpendicular displacement, change of radius, aircraft roll and flat spots (aircraft without a flight path radius) within the loop.

Deductions are as follows:

1. As stated in first paragraph, .5 point

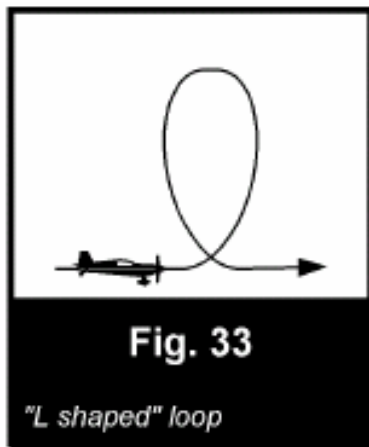

per five degrees for perpendicular displacement.

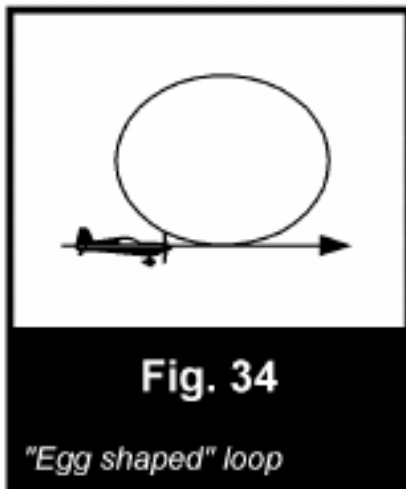

2. A variation in the radius will be a one point deduction per occurrence.
3. Aircraft displaying any roll other than during a roll element on the loop, .5 point per five degrees of roll.
4. Flight path without any radius (straight line or "flat spot"), one point per occurrence.

In judging loops, a common error is for the vertical diameter of the loop to be larger than the horizontal diameter. This is often called an "L" shaped loop (Fig. 33). Less common are loops with a horizontal diameter greater than the vertical. This is called an egg-shaped loop (Fig. 34). Another common error is in varying the radius of the final quadrant performing an "e" shaped loop (Fig. 35). The downgrades listed above should be applied for each of these errors.

If

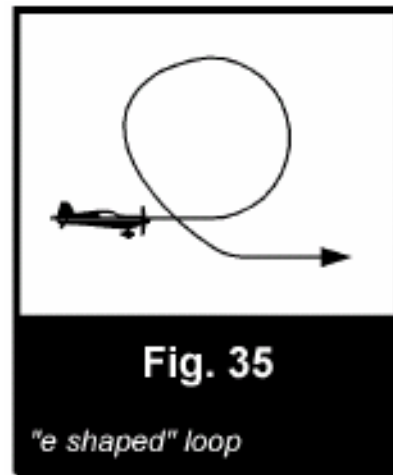

there is a rolling element (roll, point rolls or snap) at the apex of the loop, it must be centered in the loop and flown on the arc of the loop itself (Fig. 36). Flying the roll on a line at the apex of the loop is at least a two (2) point downgrade. If the roll is not centered, it must be downgraded .5 point for every five (5) degrees that it is off center.

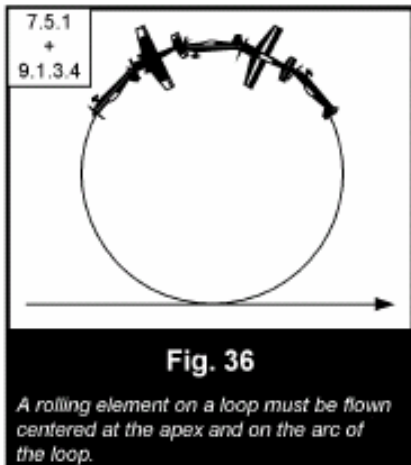

8.7.3. Family 7.7 - 7.10: Square, Diamond and Octagon Loops. Square and Octagon loops are flown as hesitation loops with lines of equal length and partial loops with equal radii (Fig. 37). Square and Octagon loops are not considered complete until the last horizontal line is drawn equal to the length of the first line of the figure.

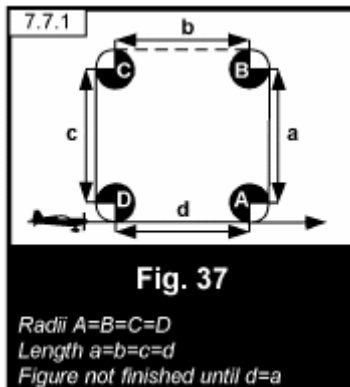

All horizontal, vertical, and 45-degree lines are judged on flight path and should therefore be wind corrected. As such, the judge should always expect to see these figures closed, the same way as a round loop.

Where rolls are flown on the Square or Diamond loops, they must be centered on the line.

Aids for judging all hesitation loops are that a good performance will contain changes of angular velocity in all the partial loops, and variations of time taken to draw the length of each interior line, which also varies according to the aircraft's speed. The rhythm of all these partial loops is a help for judging.

8.7.4. Family 7.11 - 7.12: Vertical S's. These figures are accomplished with two joined half-loops flown in opposite directions (Fig. 38).

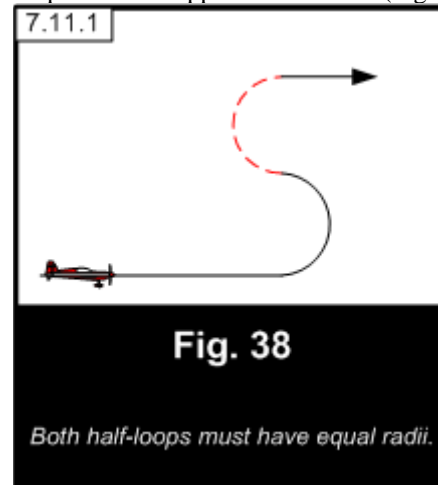

Look for both half-loops to be the same size and perfectly round. The half-loops should be a continuous looping figure when there is no half roll between the half-loops. When a half roll is performed between the half-loops (full roll(s) are not authorized), there is no line before or after the half roll. However, the half roll is flown on a horizontal line which begins as soon as the first half-loop is finished. As soon as the half roll is finished, the next half-loop must begin immediately (Fig. 39). Adding a line at either of these points is at least a two (2) point deduction, depending on the length of the line.

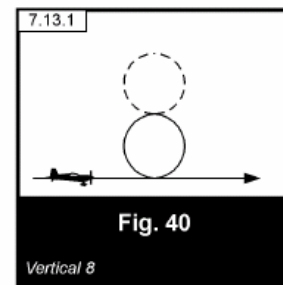
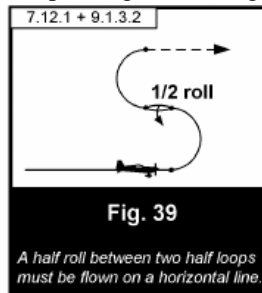

8.7.5. Family 7.13 - 7.18: Vertical Eights. These figures are performed by flying two loops, one above the other (Fig. 40). Sub-family 7.13-7.16 is composed of two loops, both above or both below the entry altitude. Sub-family 7.17 - 7.18 is composed of one loop above and one loop below the entry altitude. In either case, the entry and exit altitude must be the same.

These figures may be combined with various types of half rolls. When a half roll is performed between the loops, there is no line before or after the half roll. However, the half roll is flown on a

horizontal line that begins as soon as the first loop is finished. As soon as the half roll is finished, the next loop must begin immediately. Adding a line at either of these points is at least a two (2) point deduction depending on the length of the line. These figures are to be graded using the same criteria as full loops. Additionally, both loops must be of the same size. Unless there is a half roll between the loops, 105 they must be directly above one another. Here as well, the beginning and the end point of the maneuver will not be in the same vertical plane if a half roll is flown between the loops (Fig. 41). This should not be a reason for downgrade.

8.7.6. Family 7.19 - 7.22: Partial Eights. Sometimes referred to as "Goldfish" (Fig. 42), the entry, three-quarter (3/4) loop, and exit radii in these figures must all be identical (Fig. 43).

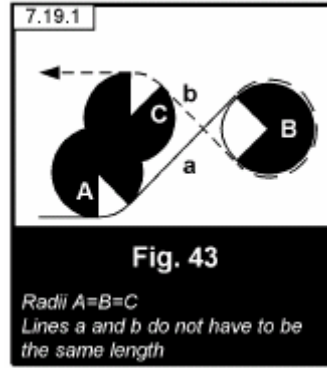
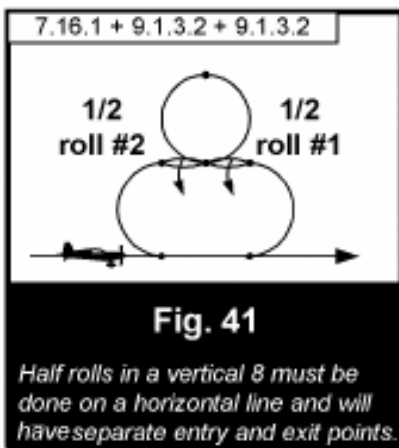
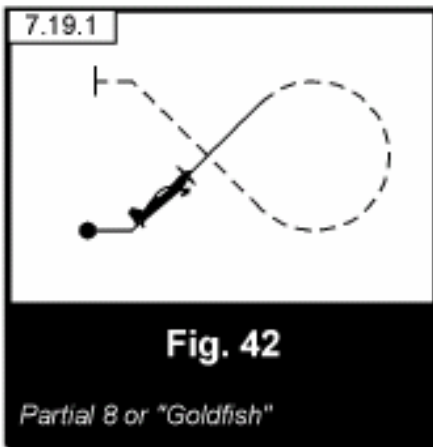

The entry and exit lines are judged with reference to the 45 degree flight path. Any rolls on the 45 degree lines must be centered on that line. It is not required that the lengths of the 45 degree lines bear any strict relation to the diameter of the three-quarter (3/4) loop. That is, the entry and exit altitudes need not correspond to the altitude limits of the loop.

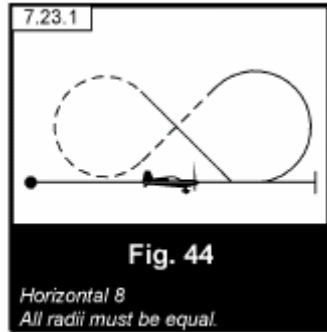

8.7.7. Family 7.23 - 7.30: Horizontal Eights. Both loops must be the same size and the lines between the loops flown at exactly 45 degrees (Fig. 44). Wind correction should be applied throughout the figure so that the 45-degree lines intersect at the exact mid-point of the Horizontal Eight. If there are rolls of any variety, they will only occur on the 45-degree lines and be positioned so that the lines before and after the roll are of equal length.

The start and finish of the figure and the bottoms (or tops if the figure is reversed) of the two loops must be at the same altitude.

All part-loops between 45 degree and horizontal lines should have the same radii as the loops of the Horizontal Eight itself. A common fault is to fly these part-loops as drawn in the catalog symbol, which means with a corner. This must be downgraded.

8.7.8. Family 7.31 - 7.38: Combination Eights. Besides possessing the unique characteristic of containing three 45-degree lines on which rolls may potentially be placed, this

family can be thought of as two linked partial Eights (sub-families 7.19 - 7.22).

Radii on the entry/exit 1/8 loop and the two 3/4 loops must all be equal. Each of the 45-degree lines may be of different lengths, but any rolls placed on them must be centered. The two 3/4 loops need not occur at the same altitude, nor is there any relationship between the horizontal entry/exit altitude and the altitude limits of the two 3/4 loops (Fig. 45).

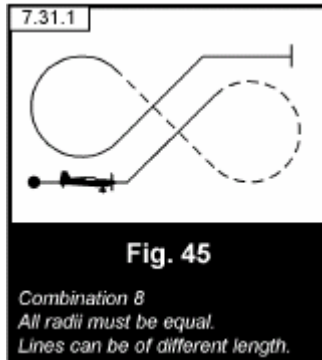

Fig. 45

*Combination 8
All radii must be equal.
Lines can be of different length.*

8.8. Family 8: Combination of Lines, Loops, and Rolls. Although some of the figures in this Family appear to be exotic, there are no new judging criteria for these figures. These figures are combinations of horizontal, vertical, and 45-degree lines as well as partial loops of varying degrees. The judging criteria for these lines and loops are unchanged. What is left to discuss are the judging criteria for the combinations of these lines and loops.

8.8.1. Family 8.1 - 8.28: Humpty Bumps. These figures, whether vertical or performed with 45-degree lines, are judged as combination of lines and loops. For all these figures, the radii of the first and last partial loop must be equal. However, the half loop in the middle of the figure can be of a different radius (Fig. 46). These half loops must still have a constant radius from the time they depart the

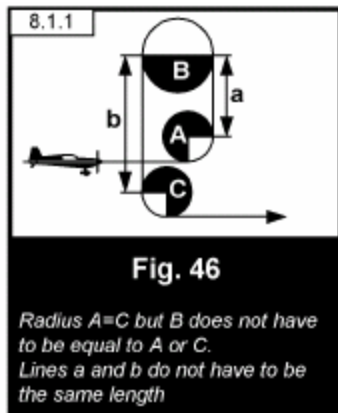

Fig. 46

*Radius A=C but B does not have to be equal to A or C.
Lines a and b do not have to be the same length*

vertical or 45-degree line. This requires a change in angular velocity during the half loop.

The lines in these figures may be of different lengths, and therefore the entry and exit altitudes of these figures can be different. Rolls on any of these lines must be centered.

8.8.2. Family 8.29-8.48 and 8.51-8.54: 7/8 Loops, Reverse Half Cuban, 3/4 Loops, Half Cubans. In these figures, all partial loops must have the same radii. When the looping portion of the figure is immediately preceded or followed by a roll or rolls, there must be no visible line between the roll and loop elements. Drawing a line requires a downgrade of at least two (2) points depending on the length of the line drawn. This criterion is not meant to imply that one element (roll or loop) must start before the preceding element is completely finished. A brief hesitation between elements (similar to opposite rolls) should not be downgraded. The rolls on vertical and 45-degree lines must be centered, except for roll(s) following a spin. If there is a roll or rolls at the apex of the loop, the roll must be centered in the loop and flown on the arc of the loop itself. Flying the roll on a line at the apex of the loop is at least a two (2) point downgrade. If the roll is not centered, it must be downgraded one (1) point for every ten (10) degrees of the arc that is off center. Angles drawn in the FAI Aerobatic Catalogue (Fig 47),

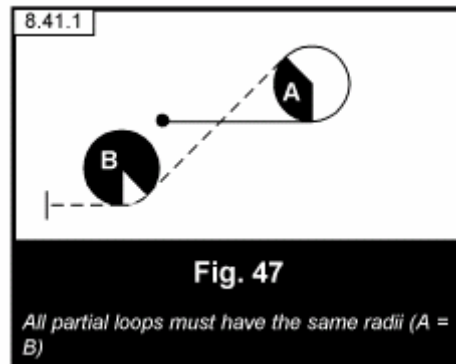
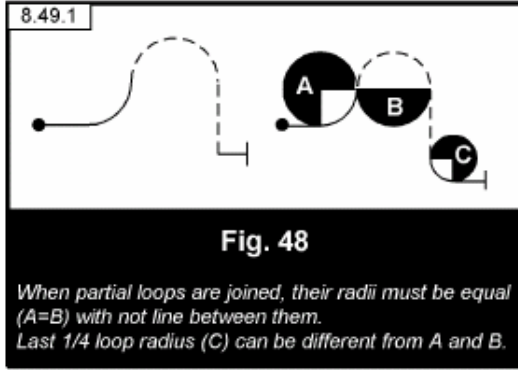

Fig. 47

All partial loops must have the same radii (A = B)

are to be flown as partial loops. In the case of this figure, a 5/8 loop is flown followed by a 45-degree downline with an optional roll and then a 3/8 loop back to upright horizontal flight.

8.8.3. Family 8.49-8.50 and 8.55-8.56: Multiple Looping Combinations. When multiple part loops join each other in these sub-families, their radii must be equal and there is no line between the loops. A line drawn would be a minimum two (2) point deduction depending on the length of the line (Fig. 48).



The 1/4 loop that returns the aircraft to horizontal flight should have a reasonable radius, but need not match the other looping radii.

8.8.4. Family 8.57 - 8.72: Teardrops. In these figures, all partial loops must have the same radii. Any rolls on vertical and 45 degree lines must be centered. Angles drawn in the FAI "Aresti System (Condensed)" (Fig. 49)

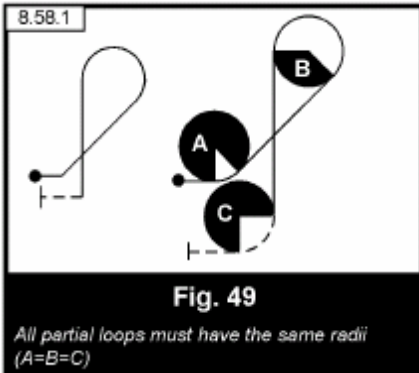

are to be flown as partial loops. In the case of this figures, a 1/8 loop is flown followed by a 45-degree line up with an optional roll. Then an inside 5/8 loop is flown and a vertical line down on which there may be another roll. Finally, an outside quarter loop is flown, bringing the aircraft back to inverted horizontal flight.

8.9. Family 9: Rotational Elements. Rolls (9.1 - 9.10) may be performed on horizontal, 45-degree or 90-degree lines, on complete loops, between part-loops, between part-loops and line, and following spin elements.

They may be 1/4, 1/2, 3/4, or a full 360 degrees in their rotation, up to two consecutive full rolls. Additionally, rolls may be flown in combination with turns as prescribed in Family 2 (Rolling Turns).

In all cases, the same criteria apply: the rate of roll must be constant throughout the roll(s). The aircraft should continue to project, during the rolling portion, the prescribed plane and direction of flight. .

Multiple rolls may be linked, unlinked or opposite:

a) When rolls are in continuous rotation, the tip of the symbols are linked by a small line. When flying linked rolls, there is no pause between them (Fig. 50). Should there be one, the figure

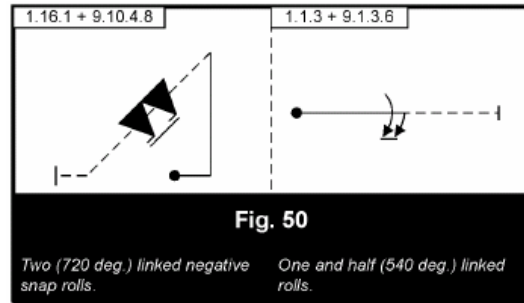

should then be zeroed.

b) Unlinked rolls must be of different types, the two types being defined as follows:

Type I: Aileron rolls (rolls and point rolls)

Type II: Snap rolls (positive and negative)

No line links the symbols, though their tips are drawn pointing in the same direction (i.e. on the same side of the line). They must have a brief but perceptible pause between them and they are to be flown in the same direction of rotation (Fig. 51).

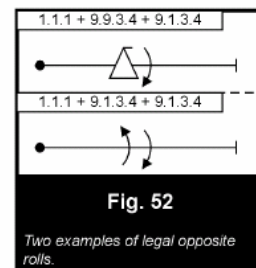
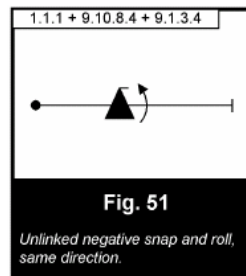

c) Opposite rolls may be either of the same or different type. In opposite rolls, the tips of the symbols are drawn on opposite sides of the line, indicating they are to be flown in opposite directions of rotation. The pilot may elect to fly the first roll in either direction, but the second roll must be the opposite direction to the first. Opposite rolls, including those in rolling turns, should be flown as one continuous maneuver - the brief pause between opposite rotations should be

minimal (Fig. 52). If the two rolls are of the same type, they must be flown in opposite direction if they are not linked.

d) Either aileron rolls or snap rolls may follow spin elements (Family 9.11 or 9.12). A spin and a roll combined on the same vertical downline will always be unlinked. They may be flown either in the same or opposite direction, as shown by the position of the tips of the symbols on the Aresti diagram. The spin will always be the first element with a maximum of two (2) turns. It can be followed by a second rotational element like a roll or a snap roll also limited to a maximum of two (2) turns (Fig. 53). Adding a third rotational element will make the maneuver illegal, i.e. a one turn spin combined with one opposite roll and one opposite half roll (Fig. 54).

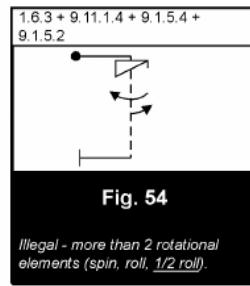
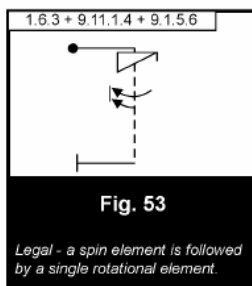

8.9.1. Family 9.1: Rolls. The penalty for varying the rate of roll is one (1) point per variation. Any stoppage in the roll that could result its being considered a point roll would zero (0) the figure.

The finish of the roll must be as crisp and precise as possible. Coming to a slow finish in fact represents a change in the rate of roll and should be penalized accordingly.

The wing must stop precisely after the desired degree of rotation and not go past the stop point and then return. This is referred to as “bumping the point” and a deduction of 0.5 points per 5 degrees should be given in this case.

8.9.2. Family 9.2 - 9.8: Point Rolls.

These rolls are judged on the same criteria as the standard roll, only the aircraft stops rotation during the roll for a pre-stated number of times, i.e. 2, 4, or 8. The rate of the roll and the rhythm of the points must be constant throughout with the aircraft projecting the pre-stated plane and direction of flight.

The pauses will be of identical duration and the degree of rotation correct between each pause: 180 degrees, 90 degrees, or 45 degrees. Each pause of a point roll must be clearly recognizable in every case. If a pause is not recognizable, the figure is graded a zero (0).

8.9.3. Family 9.9: Positive Snap Rolls.

Snap rolls represent one of the greatest challenges to judges. This is primarily due to two factors.

- I. The “snapping” characteristics of different types of aircraft are unique.
- II. Snap rolls are a high-energy maneuver that occurs very quickly. Snaps happen so fast, in fact, that it is virtually impossible for a judge to determine the exact order in which events occur, especially at the beginning of the snap. There are no criteria, therefore, for seeing nose and wing movement initiated at the same time as with the other autorotation family, i.e. Spins.

The judge must see two things to determine that a snap roll has occurred. The nose must depart the flight path in the correct directions and autorotation must be initiated. If the judge does not observe both events, the figure must be given a zero (0).

For a positive snap roll, the nose must move away from the wheels (Fig. 56). This puts

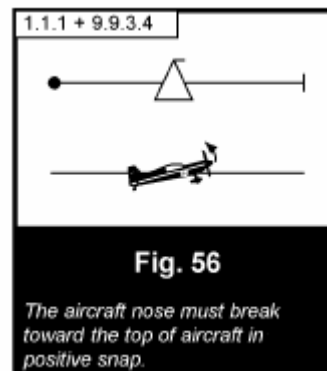

the aircraft’s wings near the critical angle-of-attack. Either very shortly after the nose moves, or simultaneously with the nose movement, the aircraft must be seen to yaw around its vertical axis, thus initiating a stall of one wing and subsequent autorotation. If any movement about the longitudinal (roll) axis is observed before the nose departs the line of flight, the figure is downgraded 0.5 points per 5 degrees.

Throughout the snap roll, the main axis of the snap roll’s rotational must be in the correct plane and direction of flight. However, the type of

motion (angle-of-attack and angular velocity) displayed around the main axis of autorotation differs between aircraft types (much as each type of aircraft has different spin characteristics). If the character of the snap roll changes during the figure, the figure is downgraded. (see Family 9..1). A changing rate of rotation or the nose moving more onto the flight path (like a roll) is the most often observed change in character. But for all aircraft types, the criteria for stopping the snap roll is the same: the attitude before starting the snap roll and in the instant of stopping it must be identical and must correspond to the geometry of the basic figure on which the snap roll is performed.

Snap rolls must be observed very carefully to ensure that the competitor is not “aileroning” the aircraft around its longitudinal axis. Aerobatic aircraft with very high rates of roll can occasionally fool a judge in the execution of snap rolls. The movement of the aircraft’s nose departing the flight path prior to autorotation is a good clue to the proper execution of snap rolls. As always, the competitor is given the benefit of the doubt, but if a judge is certain that a proper snap roll has not been executed, a zero (0) is given. Another common error is for the aircraft to autorotate, but not to stay in autorotation until the end of the figure. In this case, a deduction of 0.5 points for each 5 degrees of rotation remaining when the autorotation stops must be made. If the autorotation ends with more than 90 degrees of rotation remaining, even if the roll is completed with aileron, the snap roll is zeroed.

8.9.4. Family 9.10: Negative Snap Rolls. For negative snap rolls, all criteria stated for positive snap rolls apply except, of course, that the aircraft is in a negative rather than positive angle of attack during autorotation. Therefore, in a negative snap roll the nose of the aircraft will move toward the wheels as it departs the line of the aircraft’s flight path (Fig. 57).

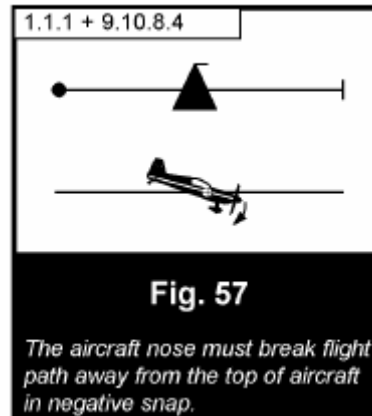

This direction of motion must be observed very carefully, since it is the defining characteristic that differentiates a negative snap roll from a positive snap roll. As with positive snap rolls, if the nose does not move in the correct direction, it is not a negative snap roll and the figure must be given a zero (0).

8.9.5. Family 9.11 - 9.12: Spins. Spin elements may be placed on a number of Family 1 and Family 8 figures (where so indicated by the optional spin symbol); however, all spins begin from horizontal flight. When the aircraft stalls, the center of gravity will drop from wings-level horizontal flight. It should be noted that the flight path should remain constant and not be influenced by the change of pitch attitude required to achieve the stall (Fig. 58).

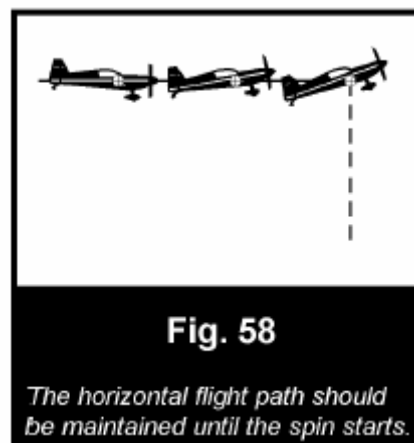

This appearance is more pronounced when the figure is performed downwind, and is enhanced when performed into the wind. This change in appearance is not a grading criterion.

Normal spins (upright spins entered from upright flight, or inverted spins entered from inverted flight): When the aircraft stalls, the nose will fall and at the same time the wing

tip will drop in the direction of the spin. Failure to achieve this should be considered a “forced entry” and downgraded 0.5 points per 5 degrees of deviation.

After completion of the prescribed number of turns, the aircraft must stop rotating precisely on the pre-stated heading, then a 90 degree downline (wind corrected if required) must be seen. Grading criteria for the basic figure being flown then resume. If a roll follows a spin, there should be a brief, but perceptible pause (similar to unlinked rolls) between the spin and the roll. Because there is no vertical line before the spin, there is no criterion to center either a spin element alone or a spin-roll combination on the vertical downline. Be alert for early stopping of the stalled autorotation followed by “aileroning” to the pre-states heading. In this case, a deduction of 0.5 points for every 5 degrees of “aileroning” must be applied. For example, in a one-turn spin the autorotation is observed to stop after 330 degrees of rotation and the ailerons are used to complete the rotation. The highest score this spin could receive is a 7.0.

No account is to be taken of the pitch attitude of the aircraft during autorotation, as some aircraft spin in a nearly vertical pitch attitude while others spins somewhat flat in conventional spins. Speed of rotation is also not a judging criterion. If the aircraft never stalls, it is apparent that it cannot spin, and a zero (0) must be given. You will see “simulated” signs where barrel rolls or snap rolls are offered as spin entries. In both cases, the flight path will not be downward. In all those cases, the figure will be zeroed.

In all spins the grading criteria are:

- a) A clean breaking stall in horizontal flight.
- b) Fully stalled autorotation.
- c) Stopping on pre-stated heading.
- d) 90 degree down, wind corrected if required vertical line after stopping on heading.

Spins are stalled maneuvers and as such, the spin part of the maneuver should not be wind corrected and judges should not downgrade any wind drift happening during the autorotation. On

the other hand, the horizontal entry line preceding the stall must be wind corrected. This means that in the case of a strong crosswind, the aircraft might be forced to “crab” in order to maintain a straight flight path. As the aircraft’s horizontal speed decreases, the crabbing angle will most probably increase and this variation in heading must not be downgraded. This variation of heading should also be included in the prescribed autorotation. For instance, if the aircraft’s heading is 30 degrees off to the left before entering a one-turn positive spin, the rotation should only be 330 degrees if doing a left turn spin (Fig. 59), or 390 degrees if doing a right turn spin.

